

# 2-TIER REVOLVING BELT RACK

ITEM # K56

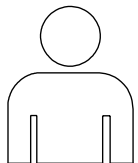
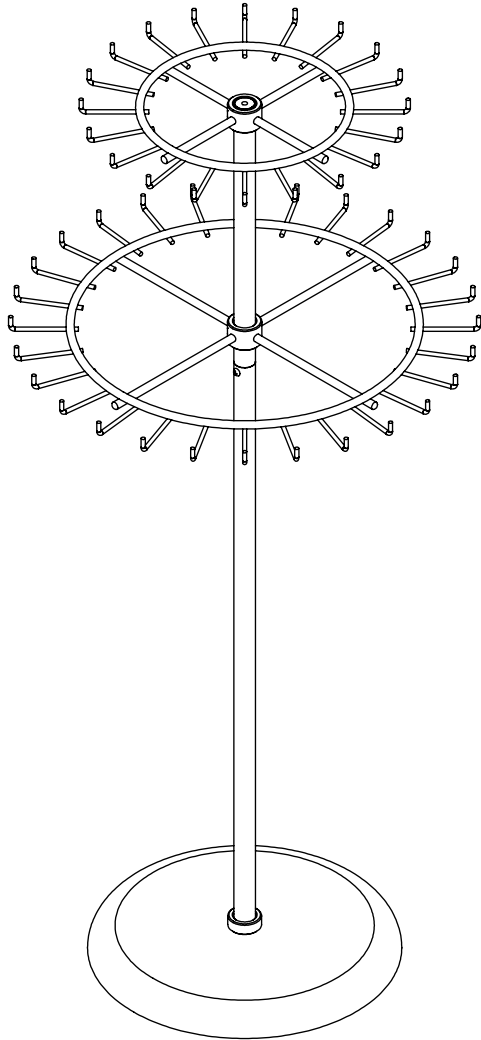

**1 PERSON  
REQUIRED  
FOR  
ASSEMBLY**

## INCLUDED HARDWARE

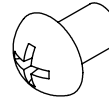

**1X**  
1/4"-20 x 0.375" LONG  
BUTTON HEAD CAP SCREW



**4X**  
3/8"-16 x 0.375" LONG  
CUP POINT SET SCREW



**1X**  
3/8" FLAT WASHER



**1X**  
3/8" LOCK WASHER

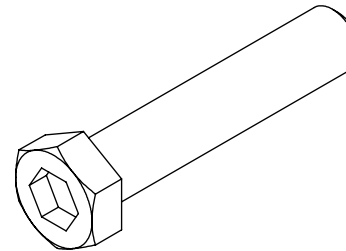

**1X**  
3/8"-16 x 1.875" LONG  
HEX BOLT

## TOOLS REQUIRED

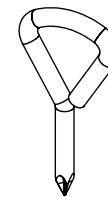

**1**

INSERT THE MIDDLE TUBE INTO THE LOWER TUBE AND SECURE WITH BUTTON HEAD CAP SCREW.

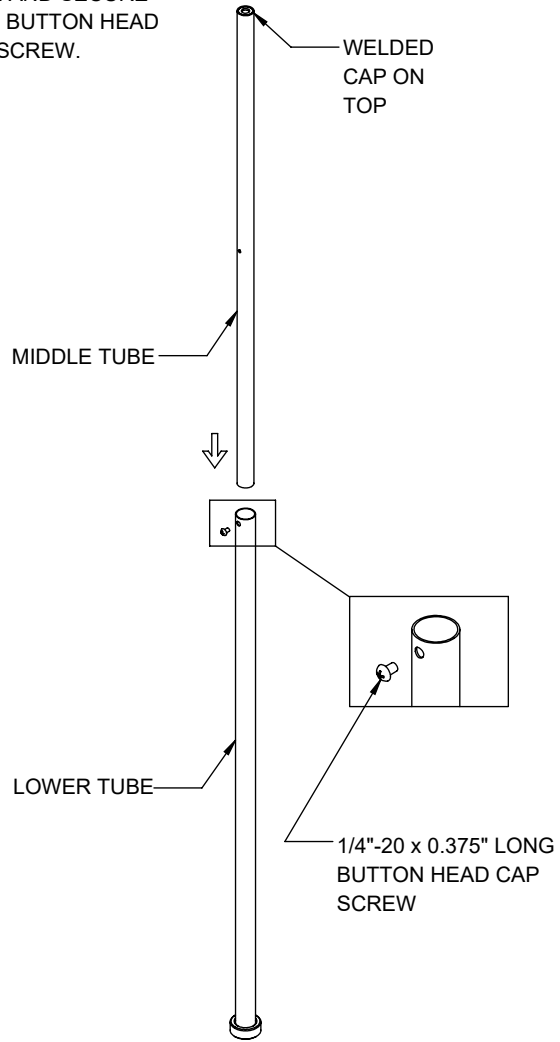

**2**

ATTACH THE ASSEMBLY FROM THE PREVIOUS STEP TO THE BASE USING THE HEX BOLT, LOCK WASHER, AND FLAT WASHER.

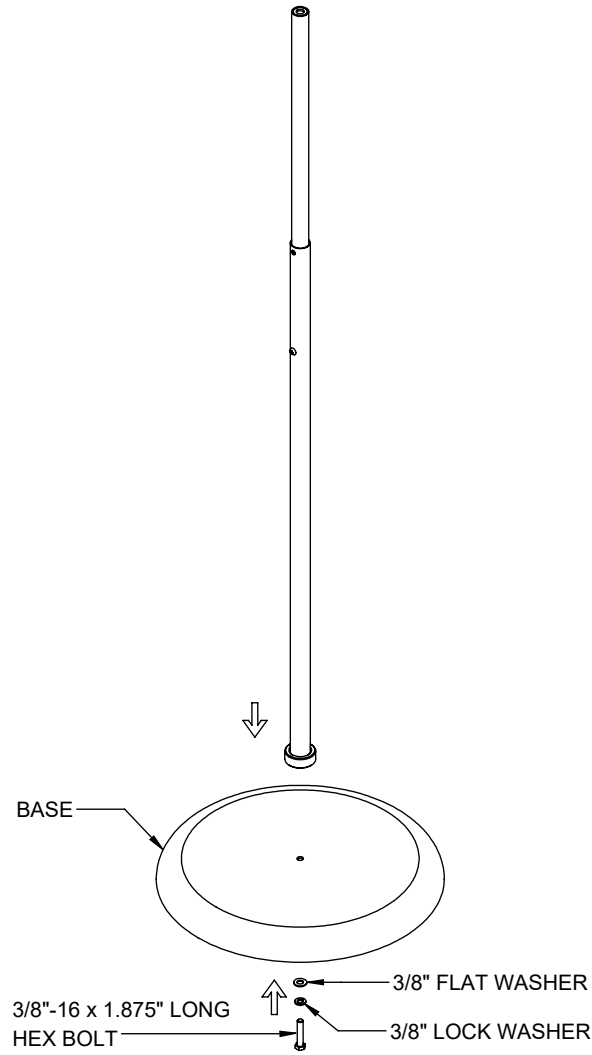

**3**

SLIDE THE UPPER TUBE ONTO THE MIDDLE TUBE.

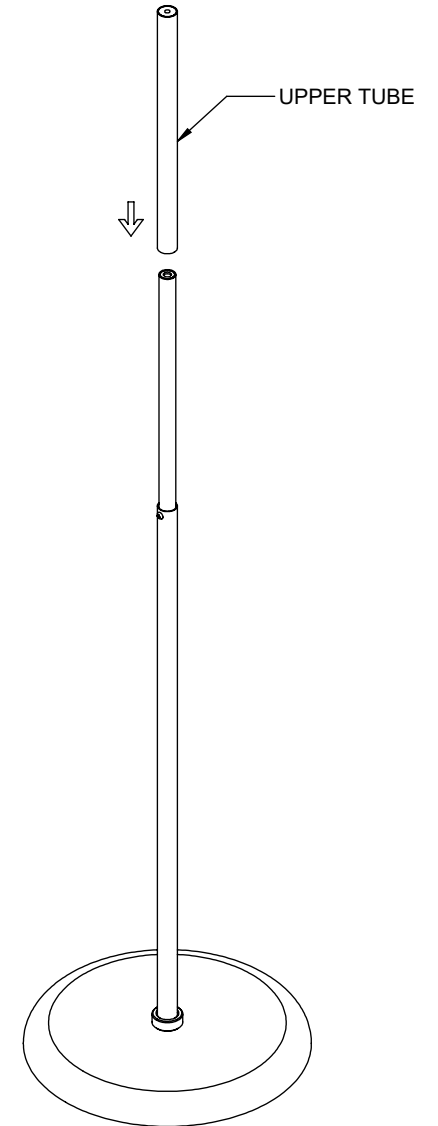

**4**

SLIDE THE LARGE  
CIRCULAR RACK ONTO THE  
UPPER TUBE AND SECURE  
WITH 2 SET SCREWS.

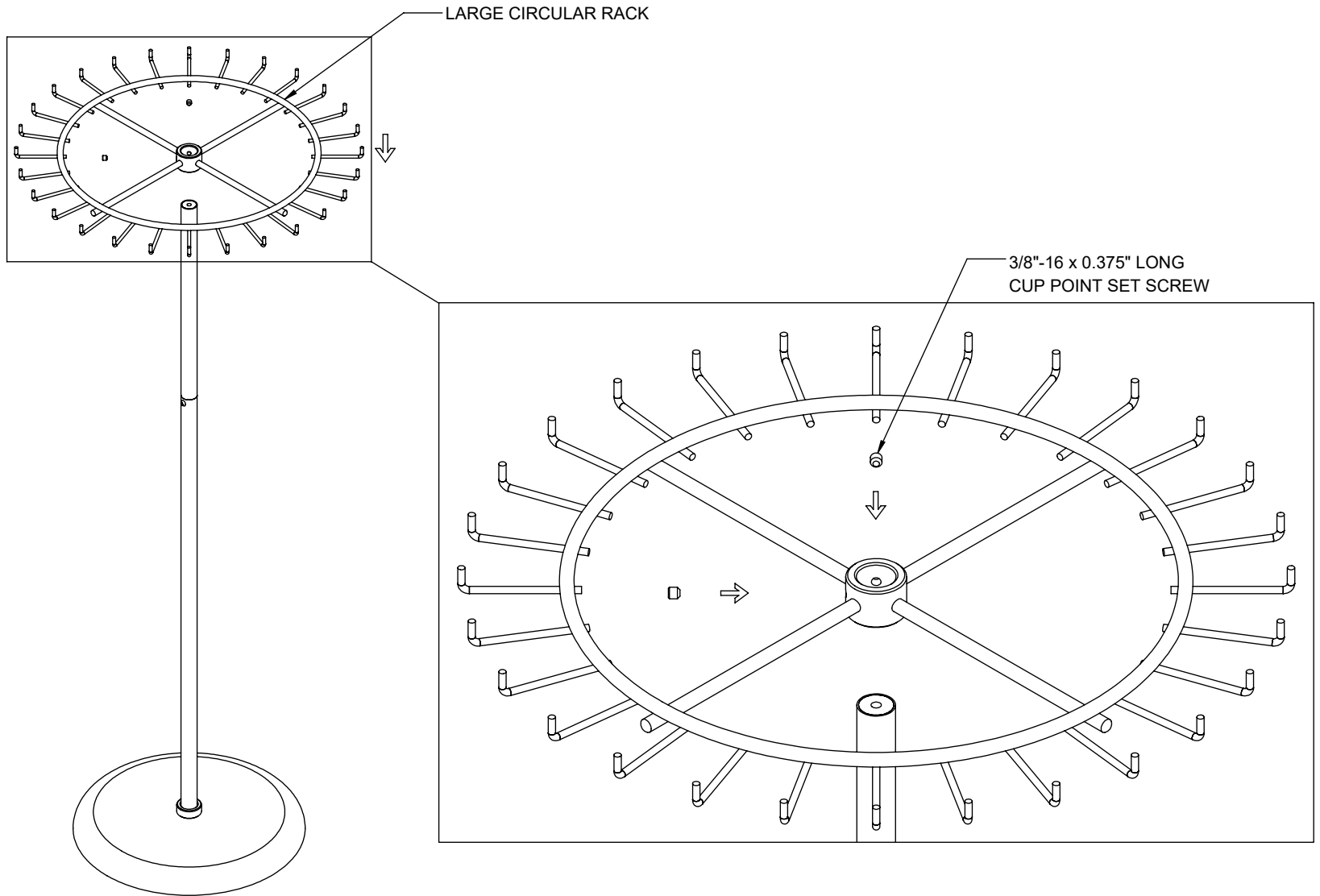

**5**

SLIDE THE SMALL  
CIRCULAR RACK ONTO THE  
UPPER TUBE AND SECURE  
WITH 2 SET SCREWS.

