

ASSEMBLY INSTRUCTIONS MANUAL

#60275 WHITE FOLDING DUMP TABLE

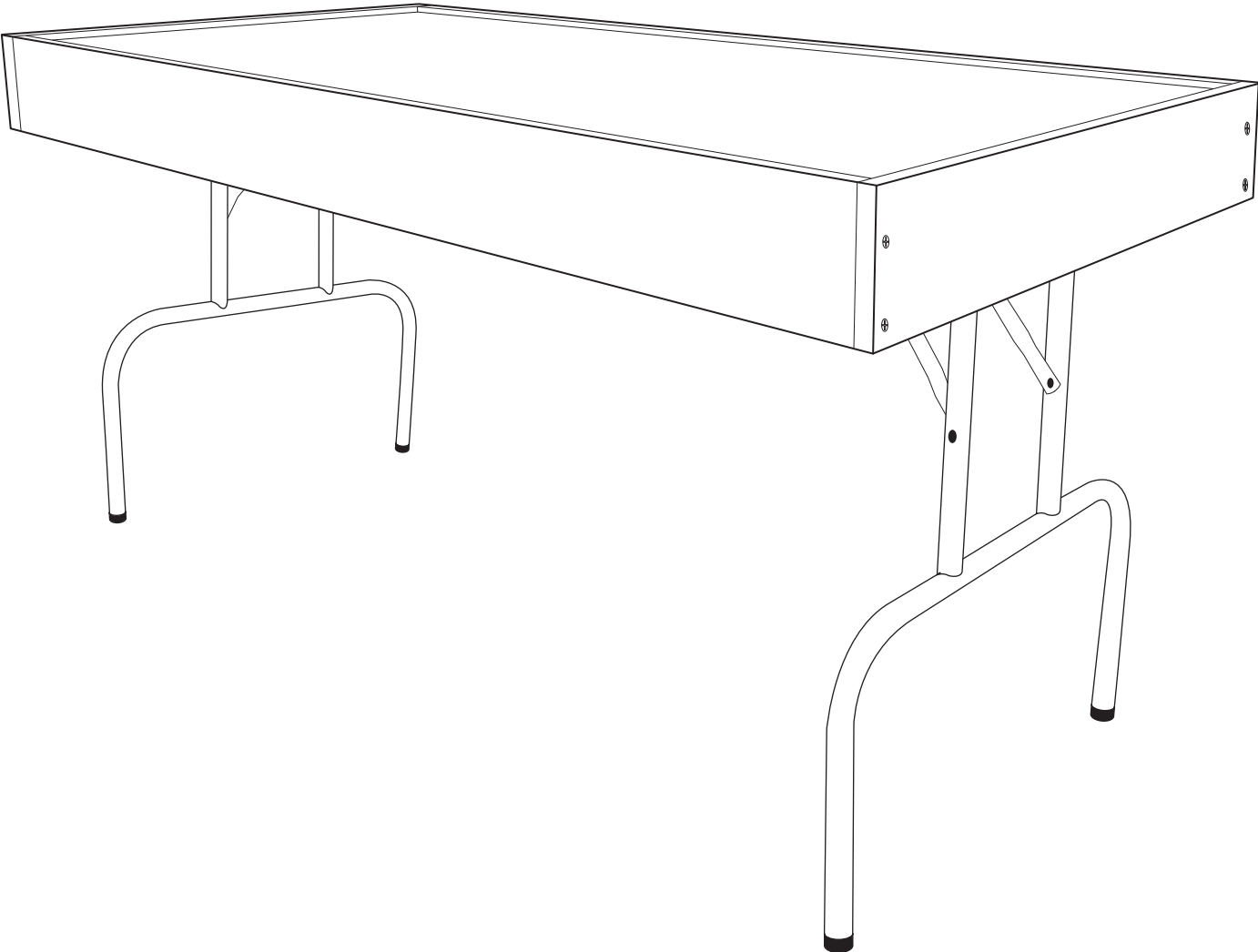

ASSEMBLY INSTRUCTIONS MANUAL

#60275 WHITE FOLDING DUMP TABLE

PARTS IN CARTON:

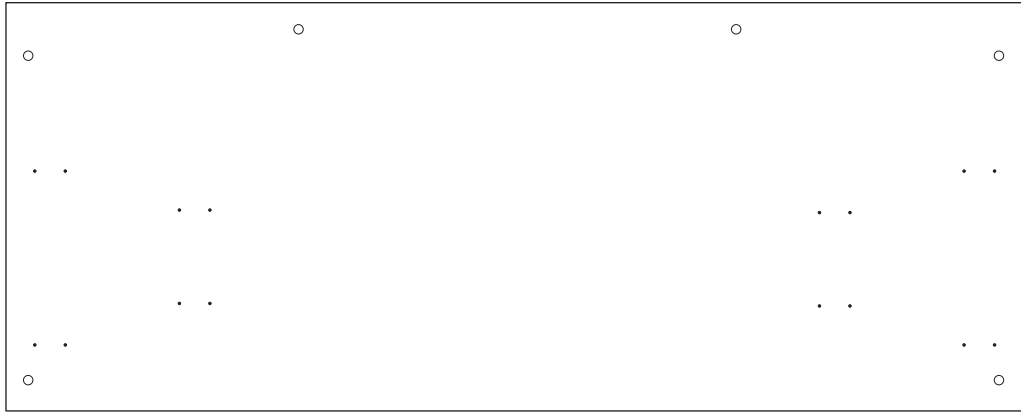
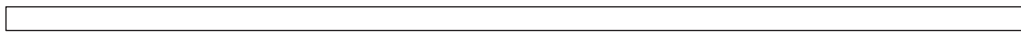

TABLE TOP
(1 EACH - BOTTOM VIEW)



JOINER STRIP
(1 EACH)



TABLE TOP EXTENDER
(1 EACH - BOTTOM VIEW)



SIDE WALL
(2 EACH - INSIDE VIEW)

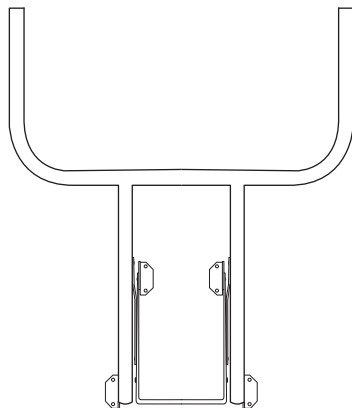

FOLD-UP LEGS
(2 EACH)

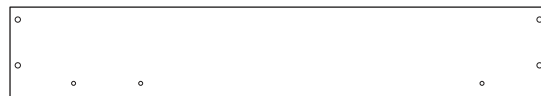

END WALL
(2 EACH - INSIDE VIEW)



END WALL
(2 EACH - OUTSIDE VIEW)

ASSEMBLY INSTRUCTIONS MANUAL

#60275 WHITE FOLDING DUMP TABLE

PARTS IN CARTON:



CAM LOCKING SCREW
(10 EACH)

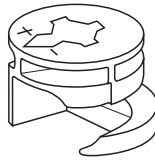
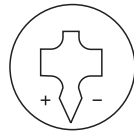

CAM LOCKING NUT
(10 EACH)



LONG SCREW
(8 EACH)

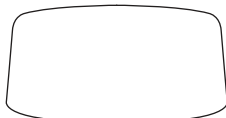

LEG CAPS
(4 EACH)



LEG SCREWS
(16 EACH)

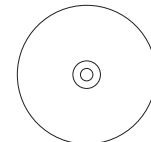

LONG SCREW COVER
(8 EACH)

YOU WILL NEED TO SUPPLY YOUR OWN SCREWDRIVER FOR INSTALLATION. INTSTALLATION WILL REQUIRE THE USE OF A SCREWDRIVER (REGULAR OR PHILLIPS-HEAD) THIS IS FOR THE INSTALLATION FOR SOME OF THE CAM LOCKING NUTS.

STANDARD PHILLIPS-HEAD SCREWDRIVER IS NEEDED FOR THE INSTALLATION OF THE LONG SCREWS, 2 INCH WOOD SCREWS AND THE CAM LOCKING SCREWS.

ASSEMBLY INSTRUCTIONS MANUAL

#60275 WHITE FOLDING DUMP TABLE

STEP 1

PLACE TABLE TOP ON FLAT SURFACE WITH BOTTOM FACING UP. SLIDE JOINER STRIP INTO SIDE OF TABLE TOP THAT HAS A RECESSED GROOVE (SEE FIGURE 1).

FOLLOW THIS STEP AGAIN INSERTING THE TABLE TOP EXTENDER INTO THE OTHER HALF OF THE JOINER STRIP THAT WAS INSERTED INTO THE TABLE TOP. IT SHOULD NOW BE ONE COMPLETE SECTION.

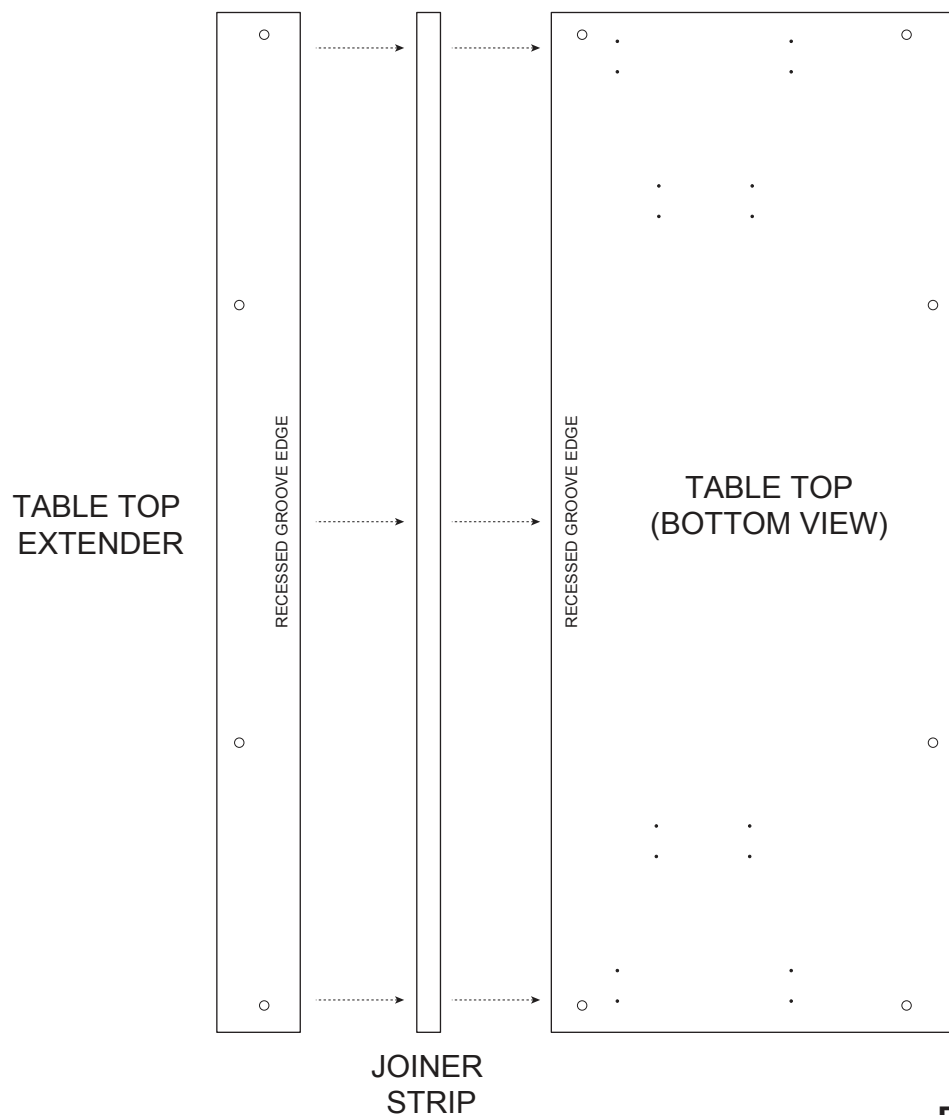
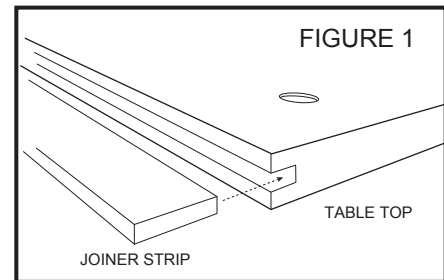

ASSEMBLY INSTRUCTIONS MANUAL

#60275 WHITE FOLDING DUMP TABLE

STEP 2

PLACE (10) CAM LOCKING NUTS INTO EACH OF THE HOLES IN THE COMPLETED TABLE TOP SECTION.

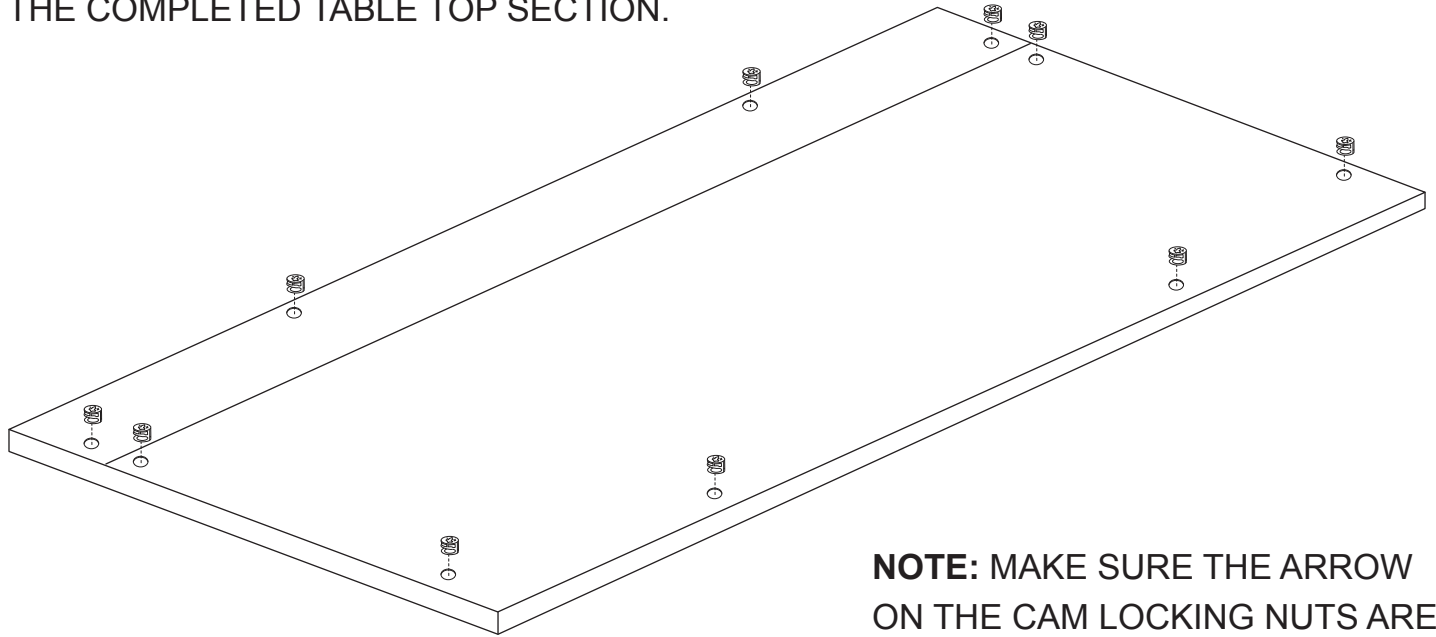

NOTE: MAKE SURE THE ARROW ON THE CAM LOCKING NUTS ARE FACING TOWARDS THE CLOSEST EDGE OF THE BOARD.

STEP 3

LOCATE (2) SIDE WALLS & (4) CAM LOCKING SCREWS. USING YOUR SCREWDRIVER, (NOT INCLUDED WITH HARDWARE, SEE PAGE 3). SCREW IN (2) CAM LOCKING SCREWS INTO THE SIDE WALL.

REPEAT STEP 3 FOR OTHER SIDE WALL.

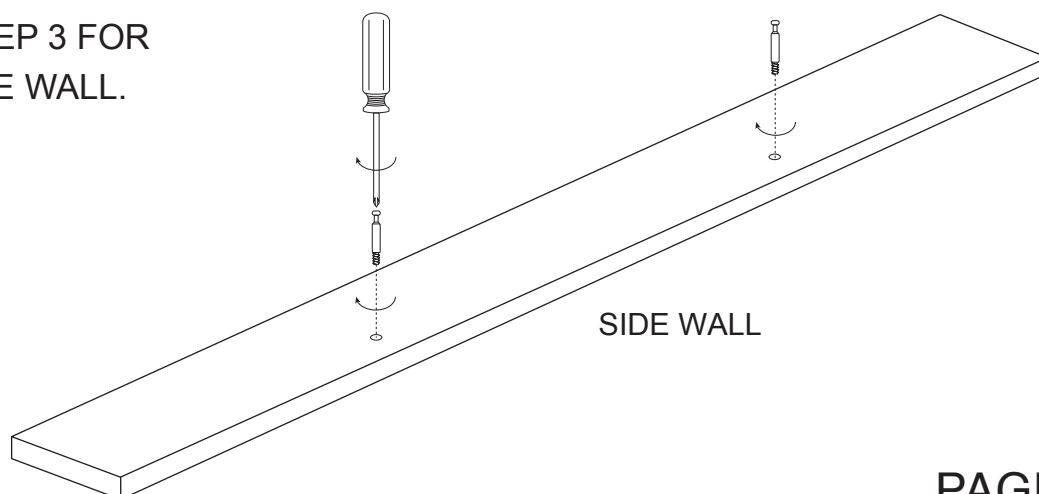

ASSEMBLY INSTRUCTIONS MANUAL

#60275 WHITE FOLDING DUMP TABLE

STEP 4

LOCATE (2) END WALLS & (6) CAM LOCKING SCREWS.
USING YOUR SCREWDRIVER, SCREW IN (3) CAM
LOCKING SCREWS INTO THE END WALL.

REPEAT STEP 4 FOR OTHER END WALL.

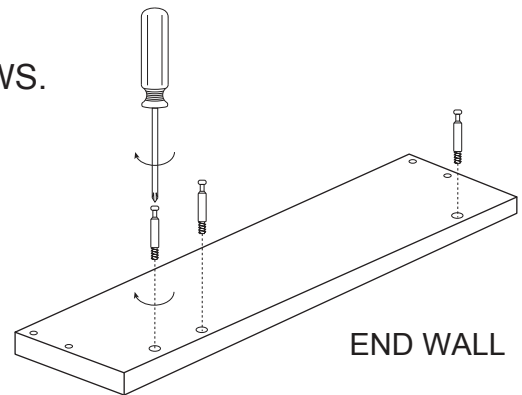

STEP 5

LOCATE (2) ASSEMBLED SIDE WALLS (FROM STEP 3) & SCREWDRIVER. INSERT
CAM LOCKING SCREWS FROM SIDE WALL INTO THE SIDE OF (TABLE TOP)
WITH THE ARROWS OF THE CAM LOCKING NUTS FACING OUT.

TO LOCK INTO PLACE: USE YOUR SCREWDRIVER TO TIGHTEN CAM
LOCKING NUTS, TURNING CLOCKWISE UNTIL TIGHT.

REPEAT STEP 5 FOR THE OTHER SIDE WALL.

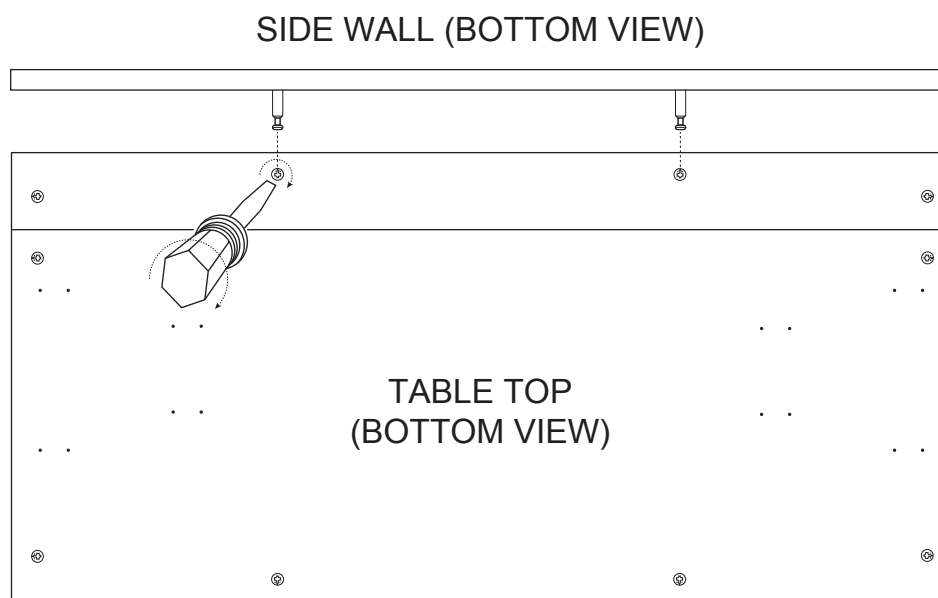

ASSEMBLY INSTRUCTIONS MANUAL

#60275 WHITE FOLDING DUMP TABLE

STEP 6

*****NOTE*** WHEN ASSEMBLING, MAKE SURE THE CAM LOCKS ARE ON THE BOTTOM SIDE OF THE TABLE.**

LOCATE (2) END WALLS. INSERT CAM LOCKING SCREWS FROM END WALL INTO THE THE SIDE WALL END. TIGHTEN ALL (3) CAM NUTS. THEN INSERT (4) LONG SCREWS INTO THE HOLES ON THE END WALL.

TO LOCK INTO PLACE: USE YOUR SCREWDRIVER TO TIGHTEN CAM LOCKING NUTS, TURNING CLOCKWISE UNTIL TIGHT.

REPEAT STEP 6 FOR THE OTHER SET OF FOLD-UP LEGS.

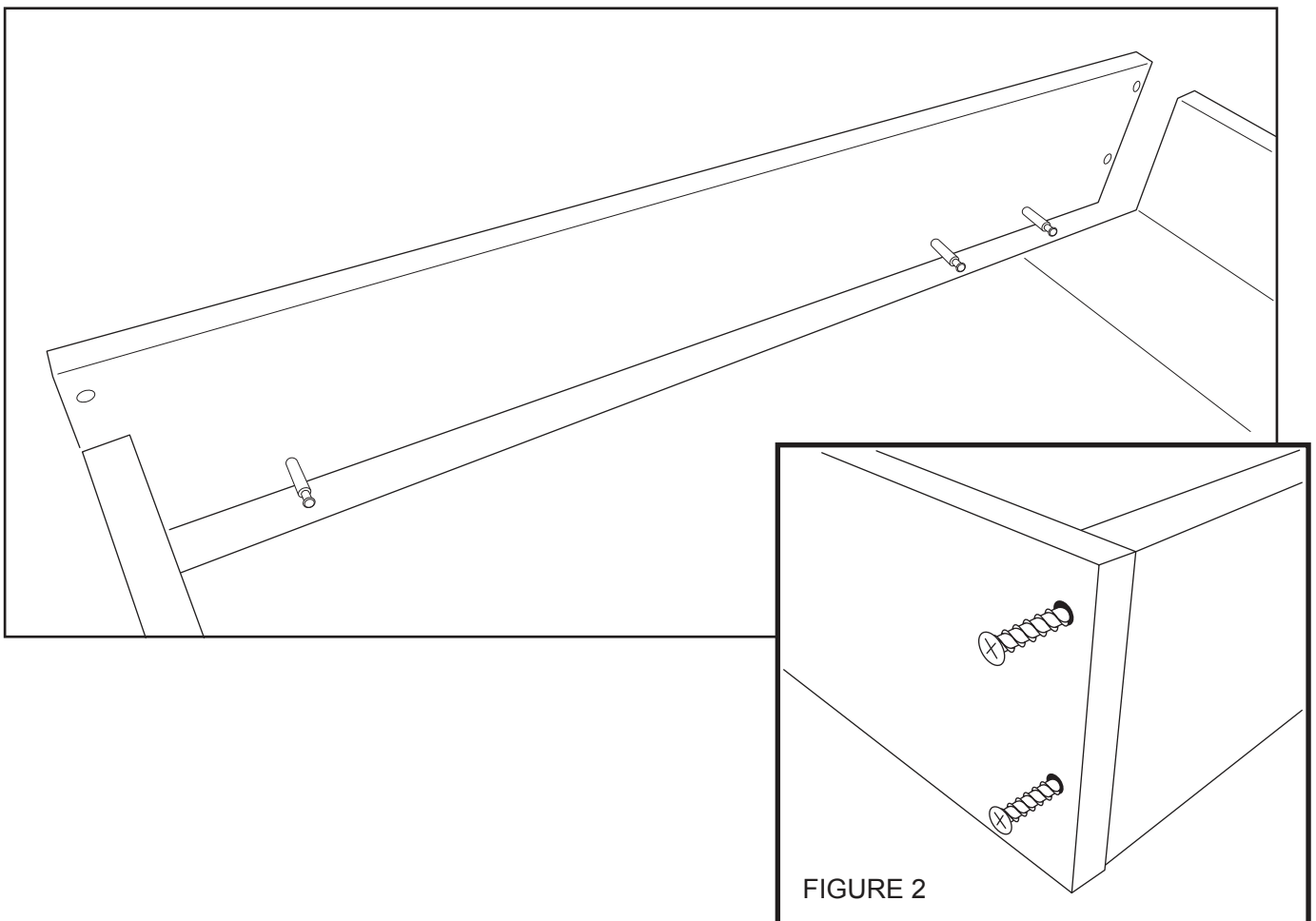

ASSEMBLY INSTRUCTIONS MANUAL

#60275 WHITE FOLDING DUMP TABLE

STEP 7

LOCATE (2) FOLD-UP LEGS & (16) LEG SCREWS. WITH TABLE TOP ASSEMBLED, PLACE (1) SET OF FOLD-UP LEGS ONTO UNDERSIDE OF TABLE TOP. ALIGN ALL (8) HOLES ON TABLE TOP TO HOLES ON FOLD-UP LEGS. USING YOUR SCREWDRIVER, SCREW IN (8) LEG SCREWS (SEE FIGURE 3).

***NOTE:** SLIGHTLY RAISE LEGS TO INSTALL THE SECOND SET OF LEGS. OPEN LEGS AND MAKE CERTAIN THAT THE LEGS LOCK INTO PLACE.

REPEAT STEP 7 FOR THE OTHER SET OF FOLD-UP LEGS.

TABLE TOP (BOTTOM VIEW)

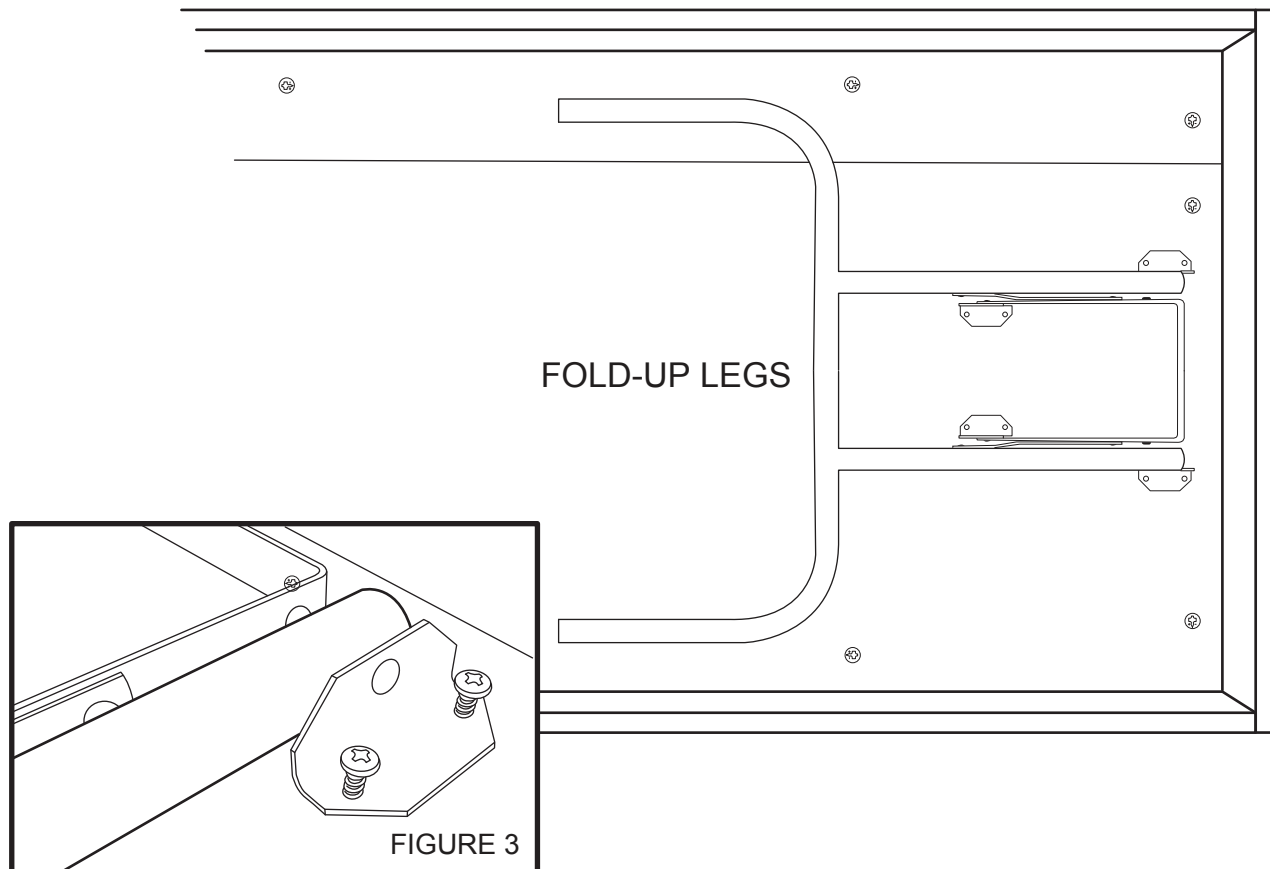

LEG SCREWS
(16 EACH)

PAGE 8 OF 9

ASSEMBLY INSTRUCTIONS MANUAL

#60275 WHITE FOLDING DUMP TABLE

STEP 8

WITH TABLE TOP STILL ON FLAT SURFACE AND LEG SECURELY OPEN, INSERT (4) LEG CAPS ONTO END OF LEGS.

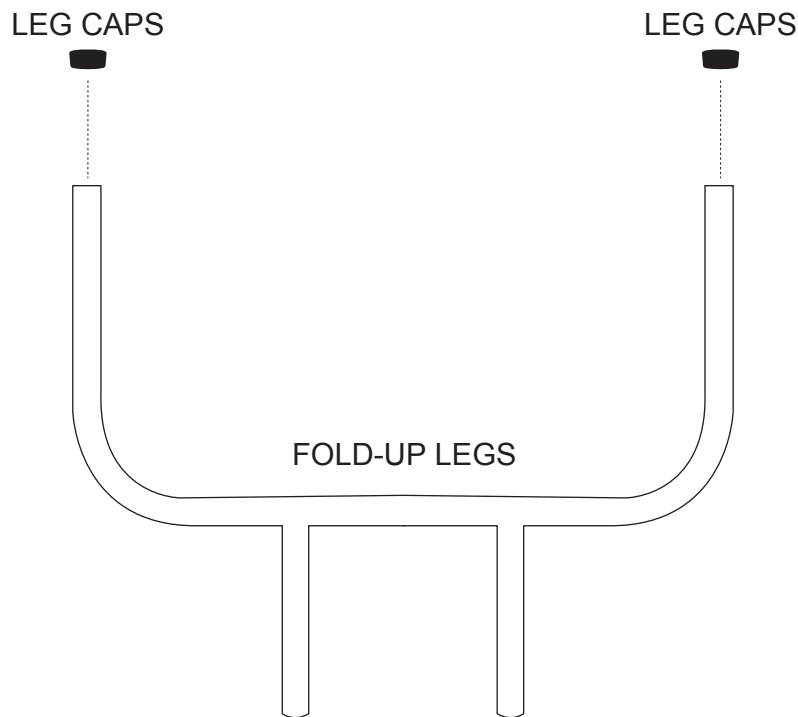

STEP 9

LOCATE (8) LONG SCREW COVERS. USING YOUR THUMB, INSERT SCREW COVER OVER EACH LONG SCREW (SEE FIGURE 4) LOCATED ON THE ENDS OF TABLE TOP ON END WALLS.

AFTER THE ASSEMBLY IS COMPLETED, TURN THE TABLE OVER ONTO LEGS (2 PEOPLE RECOMMENDED). THIS COMPLETES THE ASSEMBLY.

